

SHEATH HEATER



The right temperature in the right place.

Optimum temperatures in the required places!

We offer ideal products for your application.

Relational expression for voltage, capacity, current and resistance

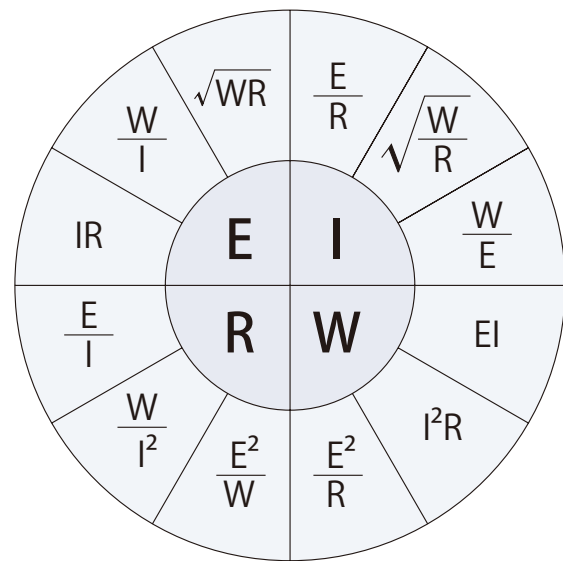

E : Voltage
I : Current
W : Watts
R : Resistance

W_2 , electric watts in use within the rated voltage

$$W_2 = W_1 \times \left(\frac{E_2}{E_1} \right)^2$$

W_2 : Watts in use E_2 : Voltage in use
 W_1 : Rated watts E_1 : Rated voltage

Example : W_2 when a 1-kW electric heater is used at 100 V instead of a rated voltage of 200 V.

$$W_2 = 1000 \times \left(\frac{100}{200} \right)^2 = 250W$$

Contents

For heating water	HP/SOP Screw Plug Heaters	2
For heating water	Immersion Tubular Heaters	3
For heating water	Tank Immersion Tubular Heaters	3
For heating water	Tubular Heaters with Bushing	4
For heating cleaning solution	TP Screw Plug Heaters	5
For heating cleaning solution	UTP Tubular Heaters (applicable to ultrasonic cleaning)	5
For heating oil	Immersion Tubular Heaters	6
For heating oil	OP/SOP Screw Plug Heaters	7
For heating gas	Straight/Tubular Heaters	8
For heating gas	U/M Tubular Heaters	8
For heating gas	Coil Finned Heaters	9
Custom heaters	Flange Heaters	10

For heating water Screw Plug Heaters

You can use the screw plug heater simply by screwing it in through an insertion hole provided on the side wall of the water tank. Screw plug heaters are cost effective and easy to use, requiring a small space for installation.

HP TYPE

- ◆ Nickel-plated copper pipes are used for the sheaths.
- ◆ HP1 to HP5 plug heaters have been wired for 200 V before shipment. If you want to use your heater at 100 V, connect the supplied shorting bar (refer to Fig. a.).
- ◆ HP6 to HP13 plug heaters have been wired for three-phase 200 V before shipment. If you want to use your heater at single-phase 200 V, connect the supplied shorting bar (refer to Fig. b.).

Phase	Voltage	Watts	Parallel thread for tube	A (mm)	B (mm)	C (mm)	D (mm)	E (φ)	Code
Single	100 / 200	1000	G1¼	200	25	22	60	47.3	HP1
Single	100 / 200	2000	G1¼	250	25	22	60	47.3	HP2
Single	100 / 200	3000	G1¼	430	25	22	60	47.3	HP3
Single	100 / 200	4000	G1½	470	20	10	65	54	HP4
Single	100 / 200	5000	G1½	550	20	10	65	54	HP5
Single/Three	200	1000	G1½	200	18	21	60.7	54	HP6
Single/Three	200	2000	G1½	250	18	21	60.7	52	HP7
Single/Three	200	3000	G1½	300	18	21	60.7	52	HP8
Single/Three	200	4000	G2	350	21	23	67	52	HP9
Single/Three	200	5000	G2	400	21	23	67	68	HP10
Single/Three	200	6000	G2	500	21	23	67	68	HP11
Single/Three	200	10000	G2	650	21	23	67	68	HP12
Single/Three	200	15000	G2	800	21	23	67	68	HP13

※Nuts are sold separately.

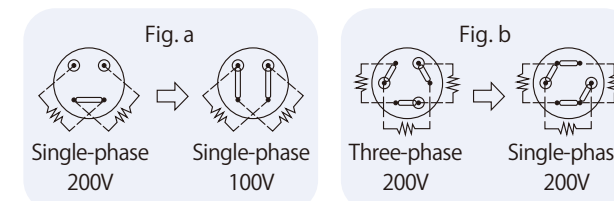

■HP1 ~ HP3 • HP6 ~ HP13 (The above image represents heater HP6 to 13.)

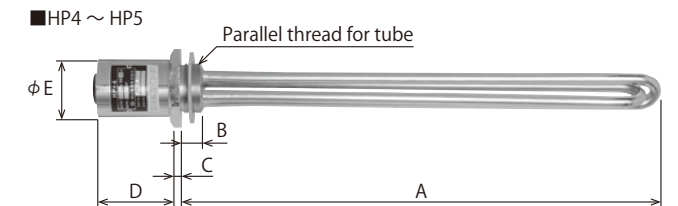
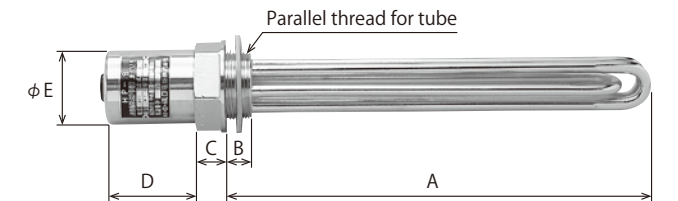

SOP type

- ◆ Stainless steel (316L, SS) is used for the sheath material.
- ◆ 304, SS is used for the plugs.
- ◆ The heaters have been wired for three-phase 200 V before shipment. If you want to use your heater at single-phase 200 V, connect the supplied shorting bar (refer to Fig. b.).

Phase	Voltage	Watts	Parallel thread for tube	A (mm)	B (φ)	C (mm)	D (mm)	E (φ)	Code
Single/Three	200	1000	G1½	250	23	15	60.7	52	SOP1
Single/Three	200	2000	G2	300	23	15	67	68	SOP2
Single/Three	200	3000	G2	350	23	15	67	68	SOP3
Single/Three	200	4000	G2	450	23	15	67	68	SOP4
Single/Three	200	5000	G2	600	23	15	67	68	SOP5
Single/Three	200	6000	G2	750	23	15	67	68	SOP6

※Nuts are sold separately.

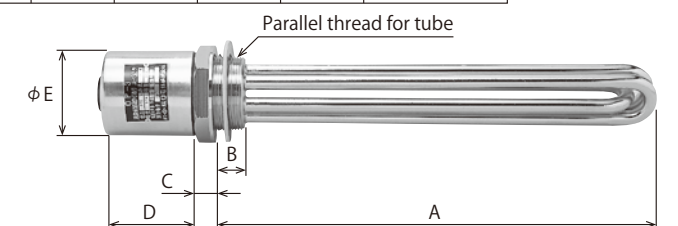
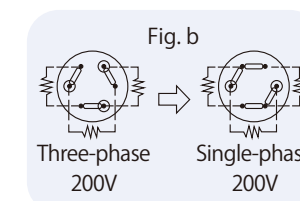

Precautions for use Screw Plug Heaters !

- Use heat-resistant wire for the lead wire. Crimp the end of the heater with the crimp terminal, and securely connect it to the plug terminal.
- Scale (e.g., water scale or oxide) will eventually form on the surface of the heating portion. Periodically inspect and clean the heater.
- Do not expose the heating portion to the air. There is a risk of fire as well as premature wire breakage.

For heating water Immersion Tubular Heaters

You can heat water simply by throwing the heater into the water tank and turning on the power supply to the heater. Heaters of this type can be used in a wide range of applications due to their ease of use.

- ◆ WHN-type heaters use nickel-plated copper pipes for the sheaths. /SNH-type heaters use stainless steel (316L, SS) for the sheath material.
- ◆ Cabtyre cable (2 m) is included.
- ◆ The hook can be rotated or removed.

Single-phase B2 type for heating water

Voltage	Watts	A (mm)	B (φ)	C (mm)	Number of turns	Sheath diameter (φ)	Grip length (L)	Grip diameter (φ)	Plug	WNH type code	SNH type code
100	300	300	70	130	2	9	88	32	A	WNH13	—
200	300	300	70	130	2	9	88	32	N/A	WNH23	—
100	500	350	75	130	2	9	88	32	A	WNH15	SNH15
200	500	350	75	130	2	9	88	32	N/A	WNH25	SNH25
100	1000	440	75	145	2	9	88	32	A	WNH110	SNH110
200	1000	440	75	145	2	9	88	32	N/A	WNH210	SNH210
100	1500	685	95	215	2	9	98	40	N/A	WNH115	—
200	1500	685	95	215	2	9	98	40	N/A	WNH215	—
100	2000	685	95	215	2	9	98	40	N/A	WNH120	SNH120
200	2000	685	95	215	2	9	98	40	N/A	WNH220	SNH220
200	3000	920	150	270	2	12	98	40	N/A	WNH230	SNH230
100	5000	980	160	300	3	12	148	47	N/A	WNH150	—
200	5000	980	160	300	3	12	98	40	N/A	WNH250	—
200	10000	980	160	300	6	12	148	47	N/A	WNH2100	—

※Heaters marked with ※ are made to order.

Three-phase B3 type for heating water

Voltage	Watts	A (mm)	B (φ)	C (mm)	Number of turns	Sheath diameter (φ)	Grip length (L)	Grip diameter (φ)	WNH type code
200	1000	450	65	195	2	9	95	40	WNH310
200	2000	650	70	215	2	9	95	40	WNH320
200	3000	750	90	235	2	9	95	40	WNH330
200	5000	950	100	255	2	9	95	40	WNH350
200	10000	1000	150	305	2	12	145	47	WNH3100
200	15000	1000	150	305	3	12	145	47	WNH3150

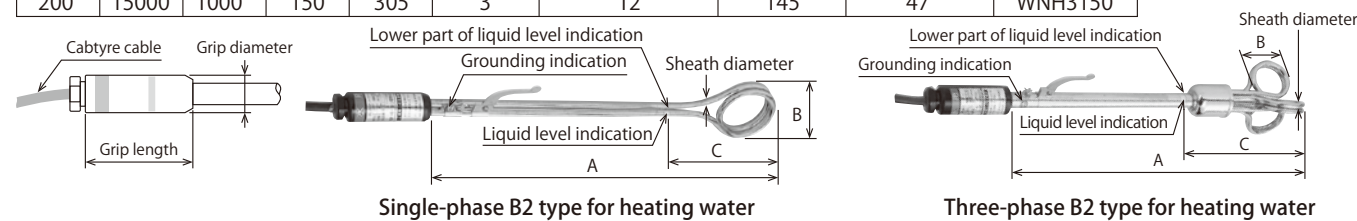

For heating water Tank Immersion Tubular heaters

Heaters of this type are suitable for heating the water in a tank or maintaining the heat of the water in the tank. The length under the neck is designed to be longer than other types of heaters of the same voltage and capacity.

- ◆ Nickel-plated copper is used for the sheath material.
- ◆ The power cord and the ground wire are each 2 m long (equipped with a plug).

Voltage	Watts	A (mm)	B (φ)	C (mm)	Number of turns	Sheath diameter (φ)	Grip length (L)	Grip diameter (φ)	Plug	Code
100	1000	800	41	60	2	9	88	32	A	FWNH110

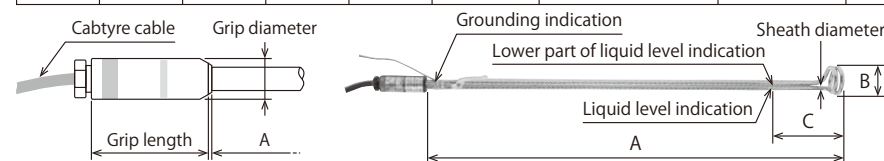

Precautions for use Immersion Tubular Heaters !

- Do not immerse the grip part in liquid. Take care that the temperature of the grip part does not exceed 70° C.
- Be sure to ground the heater when it is in use. Before applying power, make sure that the heater is immersed in the liquid up to the liquid level indication.
- Do not use the heater at a voltage exceeding the rated voltage.
- Scale (e.g., water scale or oxide) will eventually form on the surface of the heating portion. Periodically inspect and clean the heater.
- Do not expose the heating portion to the air. There is a risk of fire as well as premature wire breakage.

For heating water Tubular Heaters with Bushing

U-Tubular Heaters : Side

◆ Nickel-plated copper pipes are used for the sheaths.

Model	Voltage	Watts	A (mm)	B (mm)	Sheath diameter (φ)	Mounting screw	Code	
							100V	200V
UH-300	100/200	300	83	35	8	M12	UH13	UH23
UH-500	100/200	500	123	35	8	M12	UH15	UH25
UH-750	100/200	750	153	60	10	M13	UH175	UH275
UH-1k	100/200	1000	193	60	10	M13	UH110	UH210
UH-1.5k	100/200	1500	293	80	10	M13	UH115	UH215
UH-2k	100/200	2000	284	100	12	M16	UH120	UH220
UH-3k	200	3000	374	120	12	M16	—	UH230

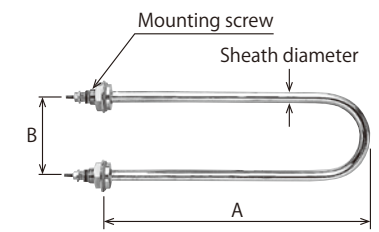

U-Tubular Heaters : Over-the-Side

◆ Nickel-plated copper pipes are used for the sheaths.

Model	Voltage	Watts	A (mm)	B (mm)	H (mm)	Sheath diameter (φ)	Mounting screw	Code	
								100V	200V
UU-300	100/200	300	70	35	28	8	M12	UU13	UU23
UU-500	100/200	500	110	35	28	8	M12	UU15	UU25
UU-750	100/200	750	140	60	28	10	M13	UU175	UH275
UU-1k	100/200	1000	180	60	28	10	M13	UU110	UH210
UU-1.5k	100/200	1500	280	80	28	10	M13	UU115	UH215
UU-2k	100/200	2000	270	100	34	12	M16	UU120	UH220
UU-3k	200	3000	360	120	34	12	M16	—	UH230

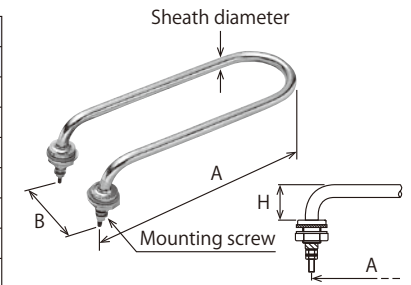

Coil Heaters

◆ Nickel-plated copper pipes are used for the sheaths.

Model	Voltage	Watts	B (mm)	E (φ)	H (mm)	Sheath diameter (φ)	Mounting screw	Code	
								100V	200V
PW-300	100/200	300	35	50	33	8	M12	PW13	PW23
PW-500	100/200	500	35	55	33	8	M12	PW15	PW25
PW-750	100/200	750	40	80	38	10	M13	PW175	PW275
PW-1k	100/200	1000	40	90	38	10	M13	PW110	PW210
PW-1.5k	100/200	1500	40	100	38	10	M13	PW115	PW215
PW-2k	100/200	2000	45	120	49	12	M16	PW120	PW220
PW-3k	100/200	3000	45	140	49	12	M16	PW130	PW230

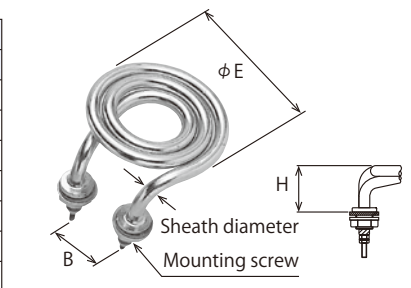

Single-Phase Flower-Shaped Heaters

◆ Nickel-plated copper pipes are used for the sheaths.

◆ The heaters are wired for 200 V before shipment. If you want to use your heater at 100 V, connect the supplied shorting bar (refer to Fig. a).

Model	Voltage	Watts	A (mm)	E (φ)	H (mm)	Sheath diameter (φ)	Parallel thread for tube	Code
P1F-1	100/200	1000	130	60	42.5	8	G1¼	PF1
P1F-1.5	100/200	1500	170	80	44	10	G1¼	PFX (※)
P1F-2	100/200	2000	190	90	44	10	G1¼	PF2
P1F-3	100/200	3000	220	95	44	10	G1¼	PF3
P1F-4	100/200	4000	240	110	44	10	G1¼	PFX (※)

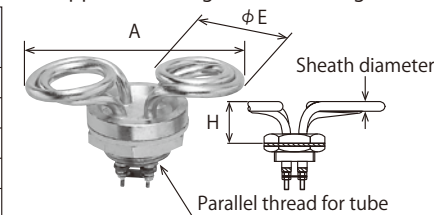

※Heaters marked with ※ are built to order.

Three-Phase Flower-Shaped Heaters

◆ Nickel-plated copper pipes are used for the sheaths.

Model	Phase	Voltage	Watts	B (mm)	H (mm)	Sheath diameter (φ)	Parallel thread for tube	Code
P3F-1	Three	200	1000	45	65	8	G1½	PF31
P3F-1.5	Three	200	1500	45	70	8	G1½	PFX (※)
P3F-2	Three	200	2000	45	95	10	G1½	PF32
P3F-3	Three	200	3000	45	105	10	G1½	PF33
P3F-4	Three	200	4000	45	115	10	G1½	PFX (※)
P3F-5	Three	200	5000	45	125	10	G1½	PFX (※)
P3F-6	Three	200	6000	45	125	10	G1½	PFX (※)

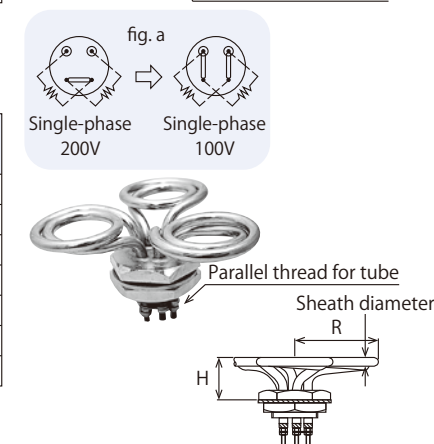

※Heaters marked with ※ are made to order.

Precautions for use Tubular Heaters with Bushing !

- Do not expose the terminal of the heater to water.
- Do not use the heater at a voltage exceeding the rated voltage.
- Scale (e.g., water scale or oxide) will eventually form on the surface of the heating portion. Periodically inspect and clean the heater.
- Do not expose the heating portion to the air. There is a risk of fire as well as premature wire breakage.

For heating cleaning solution

TP-type Screw Plug Heaters

TP-type heaters have straight-shaped sheaths. Removing the scale that has formed on the heater surface is much easier with the TP-type heater compared to the HP-type, OP-type and SOP-type heaters.

◆Stainless steel (304, SS) is used for the sheath material.

Phase	Voltage	Watts	A (mm)	B (mm)	C (mm)	D (mm)	E (φ)	Parallel thread for tube	Code
Three	200	1000	300	27	27	70	68	G2	TP1
Three	200	2000	350	27	27	70	68	G2	TP2
Three	200	3000	400	27	27	70	68	G2	TP3
Three	200	4000	500	27	27	70	68	G2	TP4
Three	200	5000	650	27	27	70	68	G2	TP5
Three	200	6000	780	27	27	70	68	G2	TP6

※Nuts are sold separately.

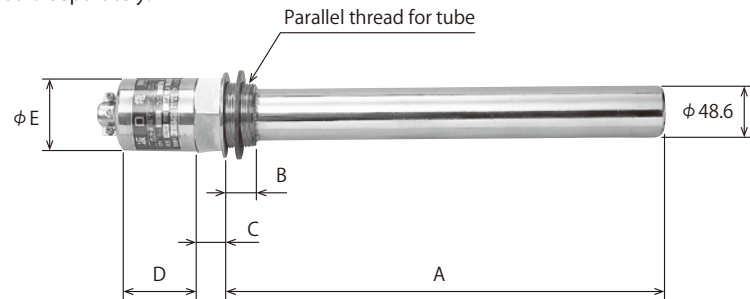

UTP-type Screw Plug Heaters

Heaters of this type are designed to handle vibrations that occur during ultrasonic cleaning.

◆Stainless steel (304, SS) is used for the sheath material.

◆The heaters are designed and manufactured so as to prevent displacement of the heating wires in the sheath during ultrasonic cleaning.

Phase	Voltage	Watts	A (mm)	B (mm)	C (mm)	D (mm)	E (φ)	Parallel thread for tube	Code
Three	200	1000	300	17	14.5	70	66.5	G2	UTP1
Three	200	2000	350	17	14.5	70	66.5	G2	UTP2
Three	200	3000	400	17	14.5	70	66.5	G2	UTP3
Three	200	4000	500	17	14.5	70	66.5	G2	UTP4
Three	200	5000	650	17	14.5	70	66.5	G2	UTP5
Three	200	6000	780	17	14.5	70	66.5	G2	UTP6

※Nuts are sold separately.

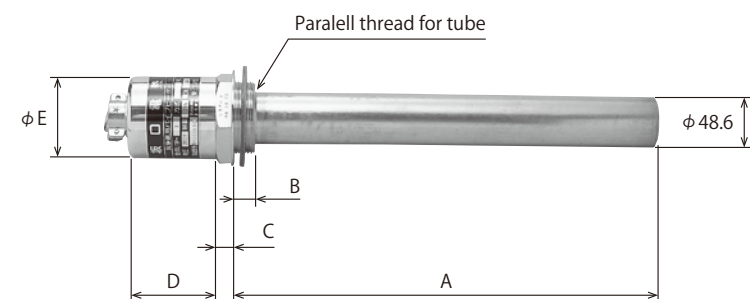

Precautions for use Screw Plug Heaters !

- Use heat-resistant wire for the lead wire. Crimp the end of the heater with the crimp terminal, and securely connect it to the plug terminal.
- Scale (e.g., water scale or oxide) will eventually form on the surface of the heating portion. Periodically inspect and clean the heater.
- Do not expose the heating portion to the air. There is a risk of fire as well as premature wire breakage.

For heating oil Immersion Tubular Heaters

Three-phase B-type ONH type

Heaters of this type are standardized products for heating oil and therefore use carefully selected materials.

◆Nickel-plated iron is used for the sheath material of the three-phase B-type ONH heaters for heating oil.

◆Cabtyre cable (2 m) is equipped.

◆The hook can be rotated or removed.

Voltage	Watts	A (mm)	B (φ)	C (mm)	Number of turns	Sheath diameter (φ)	Grip length (L)	Grip diameter (φ)	Plug	Code
200	1000	450	70	215	2	9	95	40	N/A	ONH310
200	2000	650	70	215	3	9	95	40	N/A	ONH320
200	3000	750	90	235	3	9	95	40	N/A	ONH330
200	5000	950	140	295	3	12	145	47	N/A	ONH350
200	10000	1000	150	305	4	12	145	47	N/A	ONH3110
200	15000	1000	150	305	6	12	145	47	N/A	ONH3150

Three-phase B-type SNH type

Heaters of this type are standardized products for heating oil and therefore use carefully selected materials.

◆Stainless steel (316L, SS) is used for the sheath material of the three-phase B-type SNH heaters for heating oil.

◆Cabtyre cable (2 m) is equipped.

◆The hook can be rotated or removed.

Voltage	Watts	A (mm)	B (φ)	C (mm)	Number of turns	Sheath diameter (φ)	Grip length (L)	Grip diameter (φ)	Plug	Code
200	3000	750	80	245	3	9	95	40	N/A	SNH330
200	5000	1000	130	325	3	9	95	40	N/A	SNH350

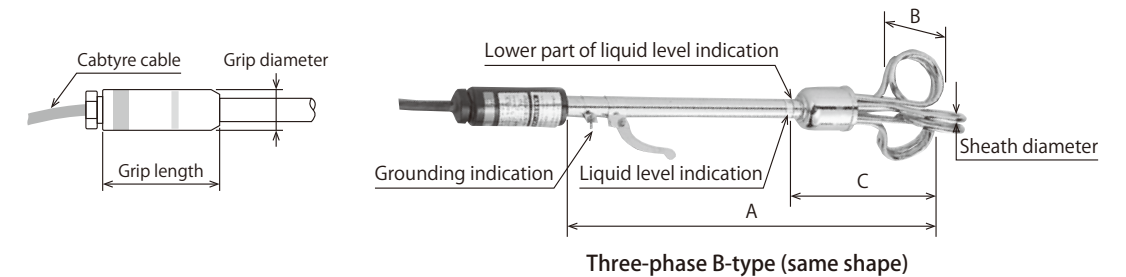

Single-phase B2-C type ONH type

Heaters of this type are standardized products for heating oil and therefore use carefully selected materials.

◆Stainless steel (304, SS) is used for the sheath material of the single-phase B2-C type heaters for heating oil.

◆Cabtyre cable (2 m) is equipped.

◆The hook can be rotated or removed.

Voltage	Watts	A (mm)	B (φ)	C (mm)	E (mm)	Number of turns	Sheath diameter (φ)	Grip length (L)	Grip diameter (φ)	Plug	Code
100	1000	500	100	100	36	2	12	98	40	A	ONH110
200	1000	500	100	100	36	2	12	98	40	N/A	ONH210
200	2000	700	100	140	72	4	12	98	40	N/A	ONH220
200	3000	800	100	230	130	6	12	98	40	N/A	ONH230

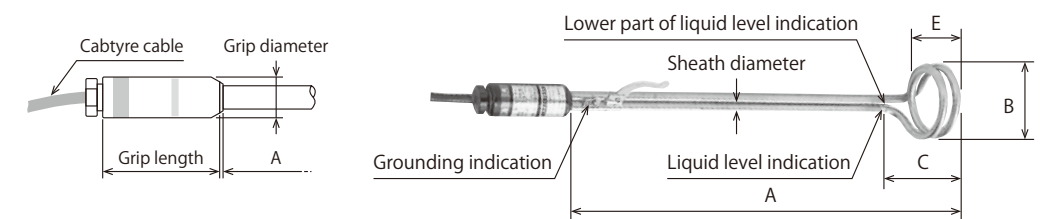

Precautions for use Throw-in Tubular Heaters !

- Do not immerse the grip part in liquid. Take care that the temperature of the grip part does not exceed 70° C.
- Be sure to ground the heater when it is in use. Before applying power, make sure that the heater is immersed in the liquid up to the liquid level indication.
- Do not use the heater at a voltage exceeding the rated voltage.
- Scale (e.g., water scale or oxide) will eventually form on the surface of the heating portion. Periodically inspect and clean the heater.
- Do not expose the heating portion to the air. There is a risk of fire as well as premature wire breakage.

For heating oil Screw Plug Heaters

Screw plug heaters are designed for heating oil.

OP type

◆Nickel-plated iron is used for the sheath material.

◆The heaters have been wired for three-phase 200 V before shipment.

If you want to use your heater at single-phase 200 V, connect the supplied shorting bar (refer to Fig. b).

Phase	Voltage	Watts	A (mm)	B (mm)	C (mm)	D (mm)	E (φ)	Parallel thread for tube	Code
Single/Three	200	1000	250	23	15	60.7	52	G1½	OP1
Single/Three	200	2000	300	23	15	67	52	G2	OP2
Single/Three	200	3000	350	23	15	67	52	G2	OP3
Single/Three	200	4000	450	23	15	67	52	G2	OP4
Single/Three	200	5000	600	23	15	67	52	G2	OP5
Single/Three	200	6000	750	23	15	67	52	G2	OP6

※Nuts are sold separately.

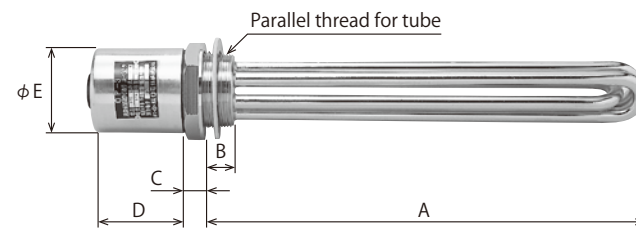
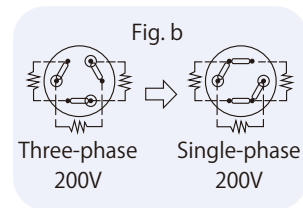

SOP type

◆Stainless steel (316L, SS) is used for the sheath material.

◆The heaters have been wired for three-phase 200 V before shipment.

If you want to use your heater at single-phase 200 V, connect the supplied shorting bar (refer to Fig. b).

Phase	Voltage	Watts	A (mm)	B (mm)	C (mm)	D (mm)	E (φ)	Parallel thread for tube	Code
Single/Three	200	1000	250	23	15	60.7	52	G1½	SOP1
Single/Three	200	2000	300	23	15	67	52	G2	SOP2
Single/Three	200	3000	350	23	15	67	52	G2	SOP3
Single/Three	200	4000	450	23	15	67	52	G2	SOP4
Single/Three	200	5000	600	23	15	67	52	G2	SOP5
Single/Three	200	6000	750	23	15	67	52	G2	SOP6

※Nuts are sold separately.

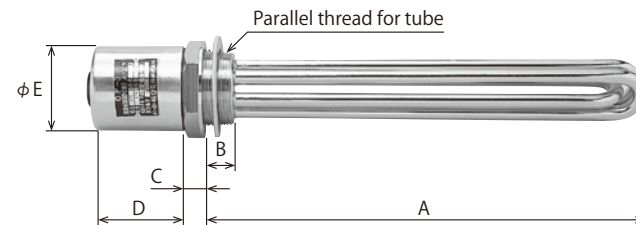
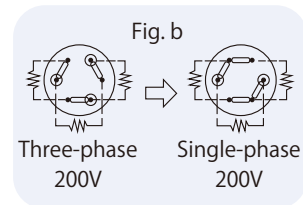

Precautions for use Screw Plug Heaters !

- Use heat-resistant wire for the lead wire. Crimp the end of the heater with the crimp terminal, and securely connect it to the plug terminal.
- Scale (e.g., water scale or oxide) will eventually form on the surface of the heating portion. Periodically inspect and clean the heater.
- Do not expose the heating portion to the air. There is a risk of fire as well as premature wire breakage.

For heating gas Straight/Tubular Heaters

Straight heaters have straight-shaped sheaths, and are available in many sizes.

Straight Heaters

◆Sheath material in stainless steel (304,SS)

Voltage	Watts	A (mm)	B (mm)	Sheath diameter (φ)	Heater terminal	Code
100	300	750	20	9	M4	STH90751
100	1000	550	20	10	M4	STH00551
200	1000	550	20	10	M4	STH00552
100	200	200	23	12	M5	STH20201
100	300	300	23	12	M5	STH20301
100	300	350	23	12	M5	STH20351
100	400	600	23	12	M5	STH20601
200	1000	800	23	12	M5	STH20801
100	300	1000	23	12	M5	STH21001
100	500	1200	23	12	M5	STH21201
100	500	1500	23	12	M5	STH21501
116	1000	350	23	14.5	M5	STH4035Y
200	1000	350	23	14.5	M5	STH4035Z
200	2000	700	23	14.5	M5	STH4070Z
100	400	600	23	16	M5	STH60601
100	800	2000	23	16	M5	STH62001
100	800	2500	23	16	M5	STH62501

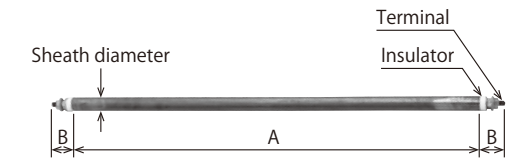

U-Tubular Heaters

◆Stainless steel (304, SS) is used for the sheath material.

Voltage	Watts	A (mm)	B (mm)	Sheath diameter (φ)	Mounting screw	Code
100	500	225	55	12	M17	SUH15
200	500	225	55	12	M17	SUH25
100	750	265	55	12	M17	SUH175
200	750	265	55	12	M17	SUH275
100	1000	315	55	12	M17	SUH110
200	1000	315	55	12	M17	SUH210
100	1500	305	60	12	M17	SUH115※
200	1500	305	60	12	M17	SUH215※
200	2000	310	60	15	M20	SUH220※

※Heaters marked with ※ are designed for heating liquid.

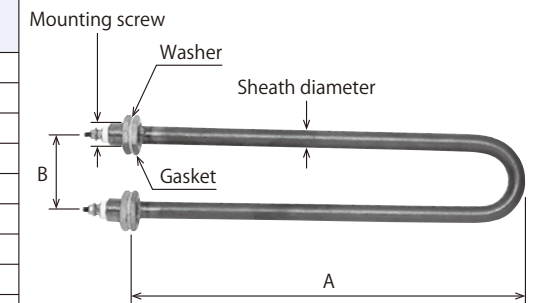

M-Tubular Heaters

◆Stainless steel (304, SS) is used for the sheath material.

Voltage	Watts	A (mm)	B (mm)	D (mm)	Sheath diameter (φ)	Code
100	300	180	90	21	7	MTH1030
100	500	250	90	21	7	MTH1050

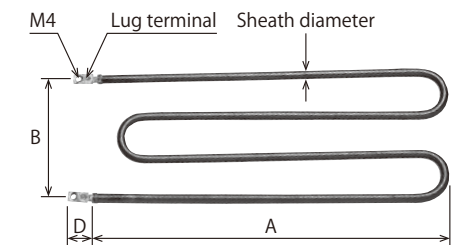

U-Tubular Heaters

◆Incoloy® is used for the sheath material.

Voltage	Watts	A (mm)	B (mm)	D (mm)	Sheath diameter (φ)	Code
100	500	300	45	20	7	CRNE105
100	1000	400	45	20	7	CRNE110
200	333	300	45	20	7	CRNE203
200	666	400	45	20	7	CRNE206
200	1000	400	45	20	7	CRNE210

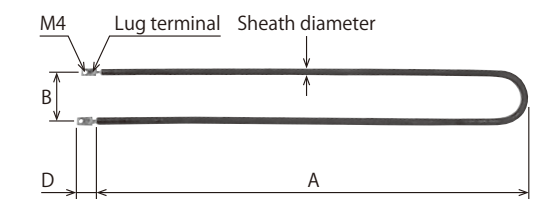

Precautions for use Straight/Tubular Heaters !

- The heater becomes hot during use and is still hot immediately after power off. Never touch a hot heater with bare hands.
- Do not use this heater at a voltage exceeding the rated voltage.
- ※Scale (e.g., water scale or oxide) will eventually form on the surface of the U-tubular heater sheath. Periodically inspect and clean the heater.
- When turning on this product in the air, the voltage and the surface temperature must be controlled while it is energized.

For heating gas Coil Finned Heaters

By winding a fin in a coil form (helicly) around a straight heater, the heat efficiency has been further improved due to the increased heat release area. Heaters of this type are durable, and best suited for heating gas.

- ◆Iron coating with heat-resistant silver powder is used for the sheath and fin materials
- ◆Mounting hardware for the heaters is also available.

Model	Voltage	Watts	L (mm)	A (mm)	B (mm)	D (mm)	Sheath diameter (φ)	Code		
								100V	115V	200V
F-1	100/115/200	300	270	210	30	28	12	F1100	F1115	F1200
F-2		300	450	390	30	28	12	F2100	F2115	F2200
F-3		500	300	240	30	28	12	F3100	F3115	F3200
F-4		500	340	280	30	28	12	F4100	F4115	F4200
F-5		500	500	440	30	28	12	F5100	F5115	F5200
F-6		750	390	330	30	28	12	F6100	F6115	F6200
F-7		750	650	590	30	28	12	F7100	F7115	F7200
F-8		1000	570	510	30	28	12	F8100	F8115	F8200
F-9		1000	950	890	30	28	12	FX(※)	F9115	F9200
F-10		333	270	210	30	28	12	F10100	F10115	F10200
F-11		333	450	390	30	28	12	F11100	F11115	F11200
F-12		667	360	300	30	28	12	F12100	F12115	F12200
F-13		667	600	540	30	28	12	F13100	F13115	F13200
F-14		833	480	420	30	28	12	F14100	F14115	F14200
F-15		833	800	740	30	28	12	FX(※)	FX(※)	F15200
F-16		1330	750	690	30	28	12	F16100	F161115	FX(※)
F-17		1330	1000	940	30	28	12			
F-18	100/115/200	1660	710	650	30	28	12			
F-19		1660	1250	1190	30	28	12			
F-20		2000	950	890	30	28	12			
F-21		2000	1380	1320	30	28	12			
F-22		3300	1250	1190	30	28	12			
F-23		3300	1450	1390	30	28	12			
F-24		5000	1750	1690	30	31	15			
F-25		5000	2200	2140	30	31	15			

※FX (built-to-order)
Note that the allowable current of available heaters is 25 A or less.

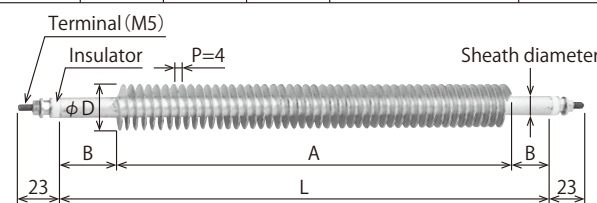

How to connect the wires

When using your heater at 200 V, connect the wires using one of the connecting methods shown below. (Heaters constructed from stainless steel are also available.)

Y connection (Star connection)

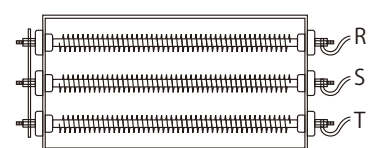

Δ connection (Delta connection)

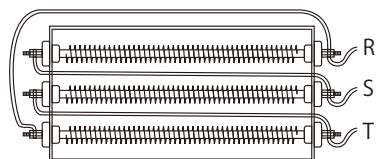

Series connection

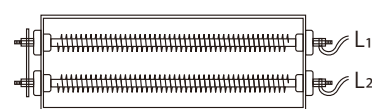

To install your heater, prepare the following thread insulators, which are sold separately.

Product Name	Code	
Steatite ceramic thread insulator M18	M18	
Standard ceramic thread insulator M20/M22 M24	Male	NG4B5B
	Female	
Standard ceramic thread insulator M24 M24	Male	NG5B5B
	Female	

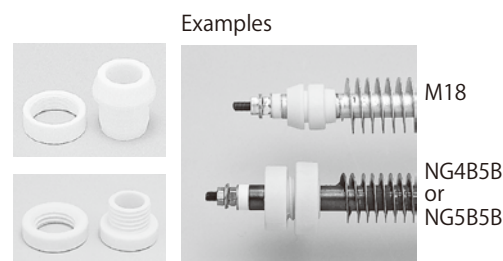

Precautions for use Coil Finned Heaters!

- Do not use the product without ventilation.
- Do not use the product at a voltage exceeding the rated voltage.
- Use the product in an atmosphere where the ambient temperature around the heater terminal does not exceed 150° C.
- The heater becomes hot during use and is still hot immediately after power off. Never touch a hot heater with bare hands.

Custom heaters Flange Heaters

As with the screw plug heaters, flange heaters can be used for heating liquid (i.e., water and oil), and for heating gas (i.e., air, gas, and steam).

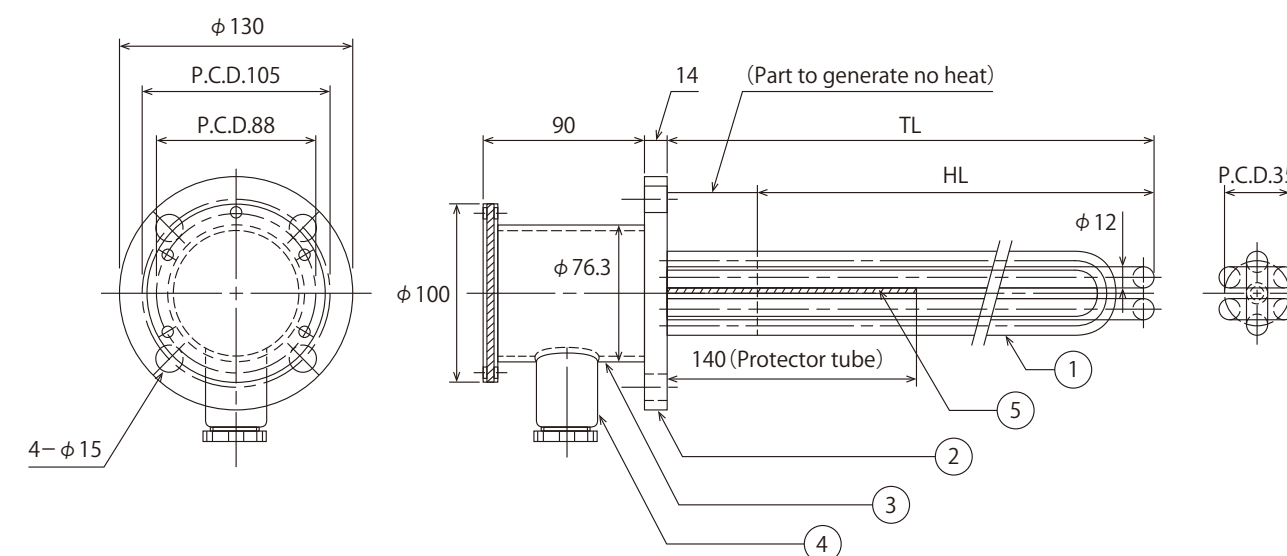
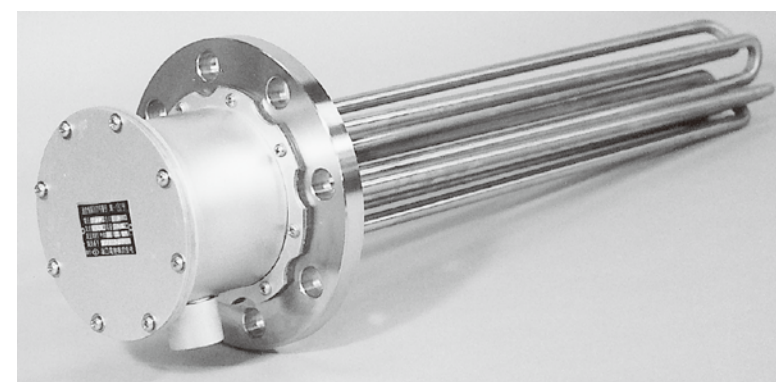

Product No.	Product	Material	Quantity	Remarks
1	Heater Sheath	316L, SS	3	φ 12
2	Flange	304, SS	1	JIS5K 50A
3	Terminal box	SGP	1set	65A (Heat-resistant silver powder coating)
4	Through hull fitting	SS	1	20-b
5	Protector tube	316L, SS	1	φ 12 × φ 10 (Protects the thermocouple from overheating)

Example of specifications

[For made to order products]

Phase	Voltage	Watts	Under head (TL) (mm)	Heating part (HL) (mm)	Watt density (W/cm ²)	Description
Three	200	1000	320	250	Approx 1.7	Standard for flange : Outer diameter of φ 130 (JIS 5 kg/cm ² , 50A, t=14) Materials : Flange (SUS304), Heater (316L, St.St.) Operating temperature : 100°C (Machine oil/Cooking oil) Others : Equipped with protection tube to prevent overheating.
Three	200	2000	370	300	Approx 2.8	
Three	200	3000	520	440	Approx 2.9	
Three	200	4000	650	580	Approx 3.0	
Three	200	5000	810	740	Approx 2.9	

- Appropriate capacity and watt density are determined according to the customer's specific application (to water, oil, gas, etc.). (Our expert design technology provides heaters best suited for your application.)
- Other specific heaters are available on request.

Precautions for use Flange Heaters!

- Use heat-resistant wire for the lead wire. Crimp the end of the heater with the crimp terminal, and securely connect it to the plug terminal.
- Regarding heaters for heating liquid, scale (e.g., water scale or oxide) will eventually form on the surface of the sheaths. Periodically inspect and clean the heater.
- Regarding heaters for heating liquid, do not expose the heater sheath to the air. There is a risk of fire as well as premature wire breakage.
- Use the product in accordance with the intended purpose.