

Specialized company for Electromagnet

FUJITA Co.,LTD.

PRODUCTS GUIDE

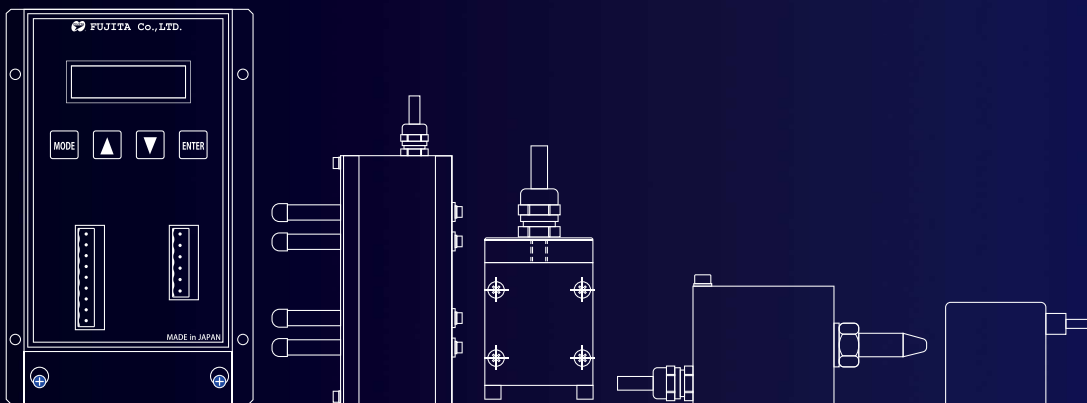

We propose and support you for introducing several electromagnetic controller and electromagnet.

High-performance electromagnetic controller meeting your needs

Stable Release in 0.2 second.

Existing electromagnets have had difficulty to release attracted workpiece stably.
Our electromagnetic controllers can stably release it in 0.2 second.

Remarkably little residual magnetism after detachment.

Our unique development enables reduction of residual magnetism of workpiece after release.

Patent granted

Free control of magnetic force of electromagnet.

Attracting magnetic force can be set according to your specification.
This enables to attract just one of piled thin steel sheets and also to attract and transfer just one of random workpieces stacked in a bucket.

You will find electromagnets suitable for your application.

Electromagnets suitable for various applications are available.

We can produce custom-made products to offer electromagnets meeting your specification.

Proposal of system using electromagnets.

We propose effective use of electromagnet meeting your site's need and support you for improvement and rationalization of working.

Collection of Applications

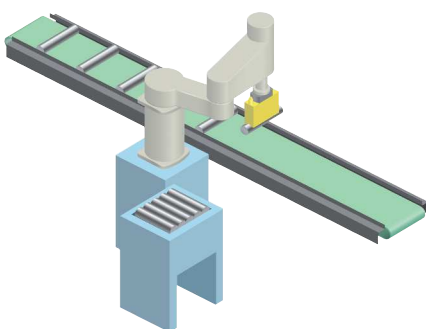

P.03

Collection of Applications

Introducing application examples of electromagnet.
You can select the most suitable model of electromagnet.

ELECTROMAGNETIC CONTROLLER



P.05

Type-FSCG



P.09

Type-FSCE

ELECTROMAGNET



P.13

Multiple floating Electromagnet
Type-FSGFM



P.16

Hourseshoe Electromagnet
Type-FSGB

systems consisting of



bars



P.14

Cylindrical
Electromagnet
Type-FSGP



P.15

Square
Electromagnet
Type-FSGK



P.17

Stick
Electromagnet
Type-FSGS



P.18

Ring
Electromagnet
Type-FSGT

Related products

P.21

Related products

Related products such as magnetic separators are available.

Collection of Applications

Combinations of Electromagnetic controller, Model FSCG or FSCE, and various kinds of electromagnet can be used for various applications.

Typical examples of applications are shown below.

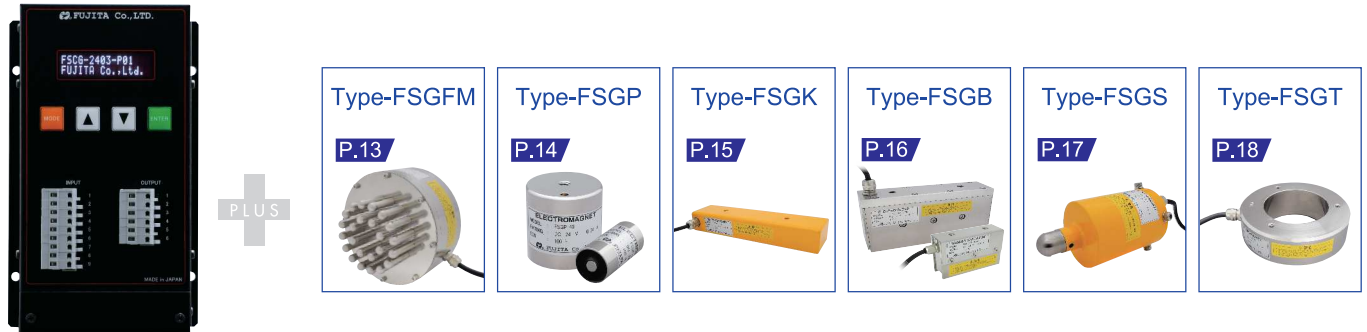

■ Attraction and transfer of one of piled steel sheets		●	●	●		
■ Attraction and transfer of press-formed article	●	●	●	●		
■ Attraction of collective random workpieces such as small parts		●	●	●	●	
■ Attraction and picking up of one random workpiece					●	
■ Attraction of round-shaped workpiece such as blank material		●	●	●		●
■ Attraction and transfer of ring-shaped workpiece		●	●	●		●
■ Attraction and transfer of shaft material				●		
■ Installed behind the belt of belt conveyor to support transfer of workpiece		●	●	●		
■ Attraction of odd-looking shaped workpiece such as castings, forgings				●	●	
■ Attraction of spherical workpiece such as iron ball	●				●	●
■ Attraction of angular materials, channel materials		●	●	●		
■ Attraction, transfer and holding of flat plate such as plate material		●	●	●		

Our products can be used for other several applications. Please feel free to contact us.

Attraction and transfer of one of piled steel sheets

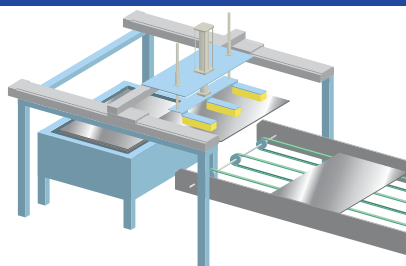

Just one of piled steel sheets can be attracted with magnetic force for one sheet, and once it is lifted up, the force is switched to be stronger.

※If workpieces stick firmly due to adhesion of oil or the like, use of Magnet separator, Model FCSF, may be required.

Attraction and transfer of press-formed article

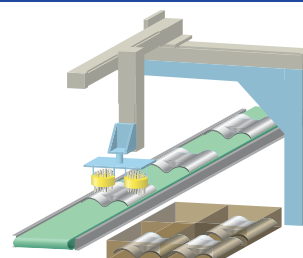

Used for transfer to a pallet in alignment and picking up, as well as assembly of press-formed article and supply to welding line.

Attraction of collective random workpieces such as small parts

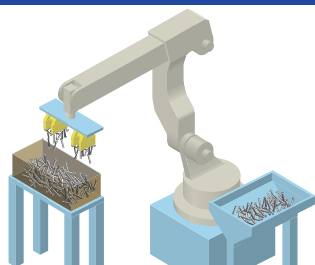

Used for collective attraction and transfer of small parts such as bolt, nut. Setting the magnetic force also sets the volume of attraction and enables stable supply of them.

Attraction and picking up of one random workpiece

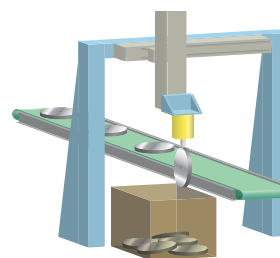

Only one of workpieces randomly contained in a paletainer can be picked up. One workpiece is attracted with magnetic force for one sheet, and once it is lifted up, it is transferred by switching the force to be strong.

Attraction and transfer of ring-shaped workpiece

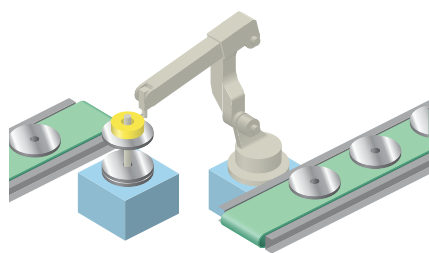

Used for attraction and transfer of ring-shaped workpiece attached to positioning shaft or cartridge.

Attraction and transfer of shaft material

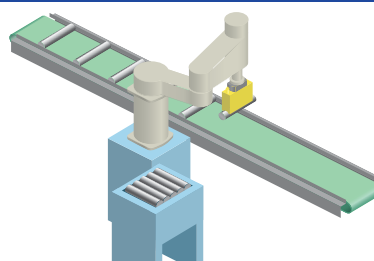

Single shaft material can be attracted and transferred. V-shaped attracting surface (※custom-made) meets various kinds of shaft diameter or length. Collective attraction and transfer of more than one shaft is also available.

Installed behind the belt of belt conveyor to support transfer of workpiece

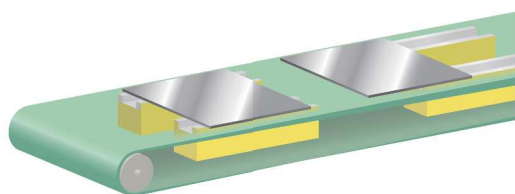

An electromagnet can be attached behind the belt of belt conveyor to hold a workpiece when transferring steel sheets. Use of electromagnet enables free change of attracting force and ON/OFF control at the position of picking up workpiece.

Attraction, transfer and holding of flat plate such as plate material

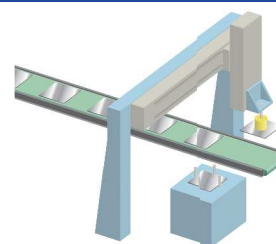

A workpiece is attracted, transferred and piled up at specified position one by one. By attracting and transferring with strong magnetic force and switching it to that for one sheet immediately before detachment, piled workpieces can be detached without lifting them.

Electromagnetic Controller

Type-FSCG



High release capability unique to FUJITA

Fujita's unique development realized very fast, stable and smooth release. Residual magnetism of workpiece after release can be reduced. (patent granted)

※This may differ depending on material of workpiece or specification of equipment.

Free control of magnetic force of electromagnet

Each condition of attraction and release can be randomly set. Maximum 15 magnetic force patterns (basic magnetic force patterns) can be set to address various specifications in detail.

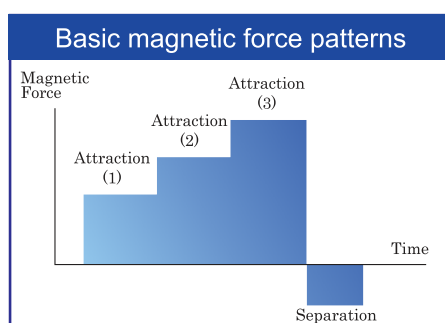

Free range of supply voltage

The voltage supplied to electromagnetic controller is single-phase, AC 100-220 V \pm 10% (allowable voltage range: AC 90-242 V), that is free range of supply voltage.

※If the output current is 10 A, the supply voltage is single-phase, AC 100 V \pm 10%.

Product specification

Power source	Rated input voltage	Single-phase, AC 100-220 V \pm 10%, 50/60Hz ※If the output current is 10 A, the supply voltage is single-phase, AC 100 V \pm 10% at 50/60Hz.
	Allowable input voltage	Single-phase, AC 90-242 V \pm 10%, 50/60Hz ※ If the output current is 10 A, the supply voltage is single-phase, AC 90-110 V \pm 10%, 50/60Hz.
	Input power supply efficiency	At least 90%
Output	Maximum output voltage	Max. DC24V (DC0V to DC24) / DC90V (DC0V to DC90V)
	Maximum output current	Max. 3A / 5A / 10A
	Control type	PWM control
Operational specification	Number of memorizable patterns	1pattern / 7patterns / 15patterns
	Pattern of input and output signal	NPN (sink logic) or PNP (source logic)
	Input signal	Optocoupler-isolated type, DC 24 V, 10 mA max. L-shaped 9-pin plug, suitable cable size of AWG28 to 12
	Output signal	Open-collector type, DC 24 V, 40 mA, attraction max. L-shaped 6-pin plug, suitable cable size of AWG28 to 12 If internal 24 V power supply used: maximum output of 250 mA If external 24 V power supply used: DC 22-27 V
	Protection circuit	For overcurrent, overload, ground fault, heat-radiating fin and undervoltage
Operating conditions	Ambient temperature	-10°C to 40°C
	Ambient humidity	10-90% RH without condensation
	Atmosphere	No corrosive or explosive gas, oil mist, dust or steam
	Vibration	Not more than 4.9 m/s ² at vibration frequency of less than 20Hz, and not more than 9.8 m/s ² at less than 50Hz
	Altitude	Not exceeding 1,000 m
Weight		2.6Kg

MODEL

MODEL	Output voltage Max.	Output current Max.	Number of memorizable patterns	Pattern of input and output signal	Power source
FSCG-2403-P1-N	DC24V	3A	1	NPN	Single-phase AC 100 to 220 V ± 10% 50/60Hz
FSCG-2403-P1-P				PNP	
FSCG-2403-P7-N			7	NPN	
FSCG-2403-P7-P				PNP	
FSCG-2403-P15-N			15	NPN	
FSCG-2403-P15-P				PNP	
FSCG-9003-P1-N	DC90V	3A	1	NPN	
FSCG-9003-P1-P				PNP	
FSCG-9003-P7-N			7	NPN	
FSCG-9003-P7-P				PNP	
FSCG-9003-P15-N			15	NPN	
FSCG-9003-P15-P				PNP	
FSCG-2405-P1-N	DC24V	5A	1	NPN	
FSCG-2405-P1-P				PNP	
FSCG-2405-P7-N			7	NPN	
FSCG-2405-P7-P				PNP	
FSCG-2405-P15-N			15	NPN	
FSCG-2405-P15-P				PNP	
FSCG-9005-P1-N	DC90V	5A	1	NPN	
FSCG-9005-P1-P				PNP	
FSCG-9005-P7-N			7	NPN	
FSCG-9005-P7-P				PNP	
FSCG-9005-P15-N			15	NPN	
FSCG-9005-P15-P				PNP	
FSCG-2410-P1-N	DC24V	10A	1	NPN	Single-phase AC 100V ± 10% 50/60Hz
FSCG-2410-P1-P				PNP	
FSCG-2410-P7-N			7	NPN	
FSCG-2410-P7-P				PNP	
FSCG-2410-P15-N			15	NPN	
FSCG-2410-P15-P				PNP	
FSCG-9010-P1-N	DC90V	10A	1	NPN	
FSCG-9010-P1-P				PNP	
FSCG-9010-P7-N			7	NPN	
FSCG-9010-P7-P				PNP	
FSCG-9010-P15-N			15	NPN	
FSCG-9010-P15-P				PNP	

Electromagnetic Controller

Type-FSCG

Improved functions to be easier to use and more convenient

RUN MODE

The process being outputted can be recognized at a glance.



PARAMETER MODE

The set parameters are more easily recognizable.



JOG MODE

Operation of panel keys enables to turn on and off the electromagnet.

It is convenient for simplified test, adjustment of equipment, etc.



I/O CHECK MODE

The status of I/O signal can be recognized at a glance.

Output signal can be forcibly turned on and off and it is convenient for adjustment of equipment.

※This mode is not available in case of RUN (during operation).



ELECTROMAGNET CURRENT CONSUMPTION MONITORING MODE

Current consumption of connected electromagnet can be recognized at a glance.

It is convenient for maintenance.



I/O MONITORING MODE

The status of I/O signal can be recognized at a glance in RUN (during operation).

It is convenient for maintenance.



ERROR RECORD CHECK MODE

Error records detected by the controller can be checked.

※Only error records can be checked, because clock function is not provided.



MODEL CHECK MODE

The models of controller can be checked at a glance.



Terminal connection diagram

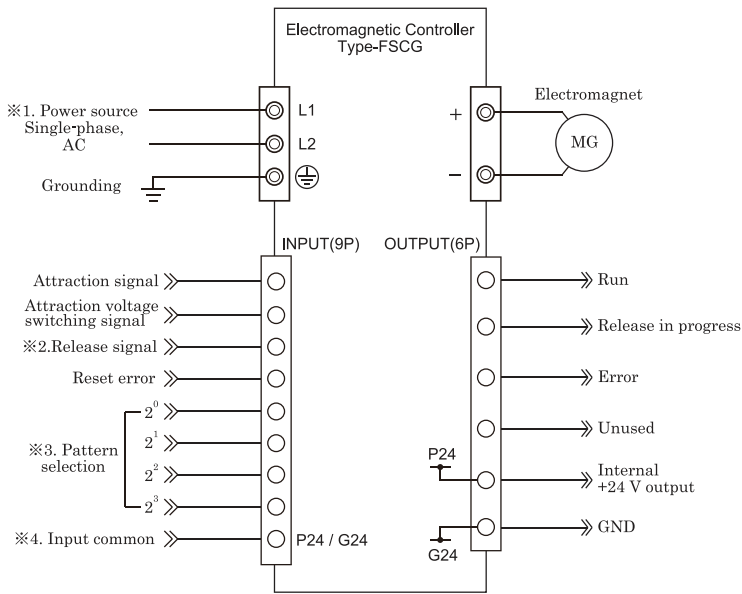

- ※1.The supply voltage differs depending on the model.
- ※2.To make the release signal valid or invalid can be selected by parameter.
- ※3.The port of pattern selection signal differs depending on the model.
- ※4.Pin No. 9 input common is GND (G24) in case of NPN and +24 V(P24) in case of PNP.
- ※5.When an external power source is used,do not connect the terminal P24.

Outer dimension

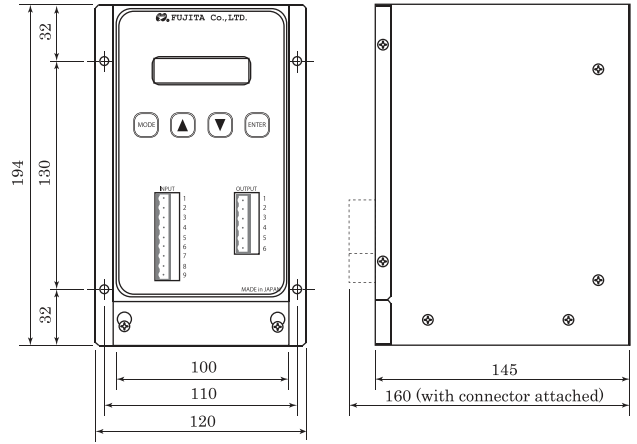

Internal circuit for I/O signal

	Internal circuit for input signal	Internal circuit for output signal
NPN	<p>Pin No.1 to 8</p> <p>Pin No.9</p> <p>2.2kΩ</p> <p>10mA Max</p> <p>P24, VCC, G24</p>	<p>Pin No.5 Internal +24V output</p> <p>Pin No.1 to 3</p> <p>Pin No.6 (GND)</p> <p>40mA Max</p> <p>P24, VCC, G24</p>
PNP	<p>Pin No.1 to 8</p> <p>Pin No.9</p> <p>2.2kΩ</p> <p>10mA Max</p> <p>VCC, G24, P24</p>	<p>Pin No.5 Internal +24V output</p> <p>Pin No.1 to 3</p> <p>Pin No.6 (GND)</p> <p>40mA Max</p> <p>P24, VCC, G24</p>

Electromagnetic Controller

Type-FSCE-2002

Low price & Compact

But no change of high detachment capability

FSCE-2402



※Image

Low price & Compact

Elimination of supply voltage conversion circuit and limitation of functions reduced approximate 70% of cost in comparison with the electromagnetic controller FSCG model.

Extra compact design (71 mm (W) × 90 mm (H) × 58 mm (D)) saves space. It can easily fit to DIN rail with a single motion.

Smooth Release

Release control, the greatest feature of the electromagnetic controller, is not changed.

Our unique development enabled fast and stable release and it reduces residual magnetism of workpiece after release.

《Patent granted》

※The reduction may differ depending on the specification of workpiece or equipment.

Easy Setting

When you adjust the magnetic force for attraction or release, the volume and rotary switch serve you to set it easily and in detail according to the specification.

Product specification

Power source	Rated input voltage	DC24V
	Allowable voltage range	DC22.8V to 25.2V
	Efficiency of input power	At least 95%
Output	Maximum output voltage	About (power supply input voltage × 0.98) V
	Maximum output current	MAX. 2A
Operational specification	Control type	PWM control
	External input signal	Optocoupler-isolated type, negative common Two points (DC 24 V, 10 mA max.)
	External output signal	Optocoupler-isolated type Two points (open-collector DC 24 V, 20 mA max.)
Control specification	Attraction voltage	Adjustment from 0-100% by the volume
	Release voltage	Adjustment from 0-100% by the volume
	Release time	Hexadecimal rotary switch
	Display	Three indications by LED: POWER, RUN, ERROR
Construction	Outer dimension	W71mm × H90mm × D58mm
	Installation	Exclusive for DIN [IEC] rail
	Weight	0.13Kg

Outer dimension

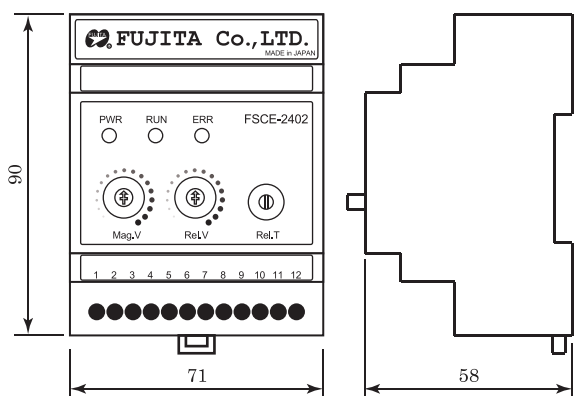

Output time chart

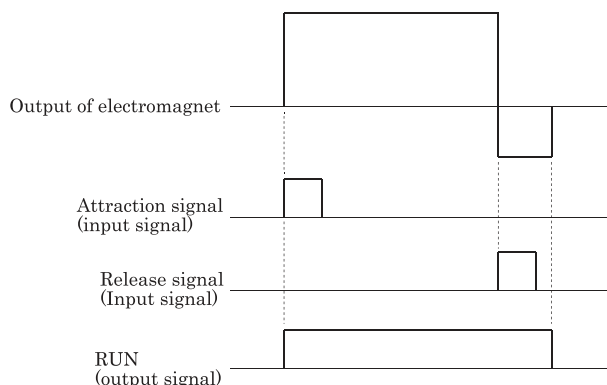

Name of each part

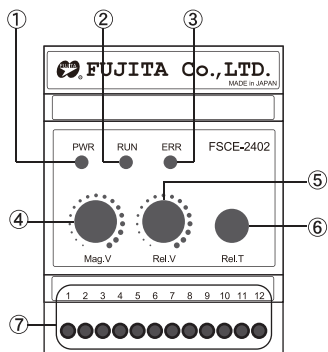

Number	Symbol	Name
①	PWR	Power on indicated by LED
②	RUN	Run indicated by LED
③	ERR	Error indicated by LED
④	Mag.V	Volume for adjustment of attraction voltage
⑤	Rel.V	Volume for adjustment of release voltage
⑥	Rel.T	Rotary switch for setting release time
⑦	1 to 12	Terminal block

Terminal connection diagram

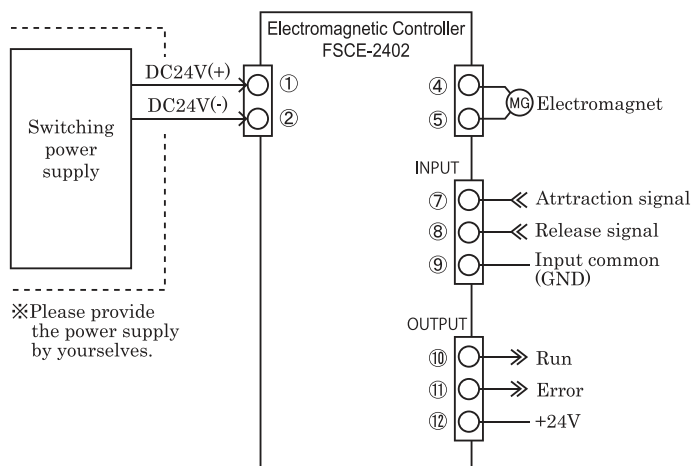

Internal circuit for I/O signal

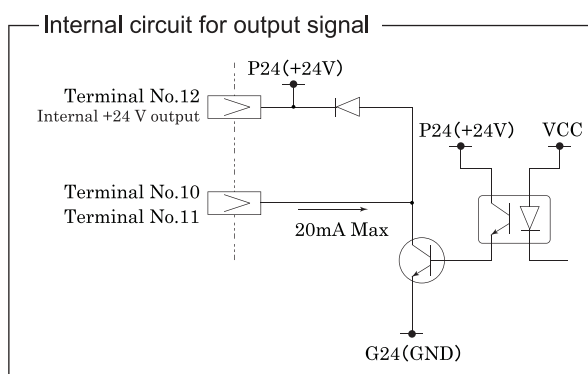
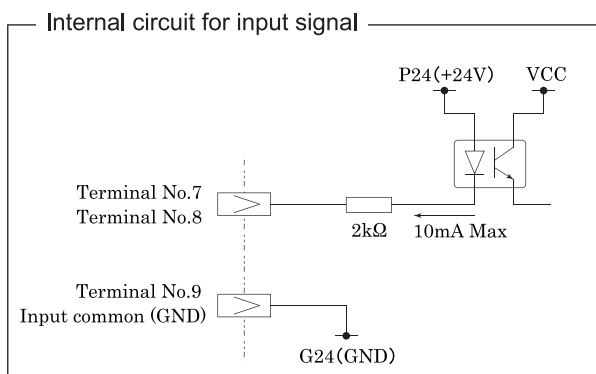

Important information on Electromagnetic Controller

For correct use of the electromagnetic controller, be sure to read carefully these “Safety Precautions” and Instruction Manual packaged with the product before installation, operation, maintenance and inspection of it.
In this manual, the safety precautions are classified into “WARNING” and “CAUTION”.



WARNING

Mishandling may cause hazardous situations resulting in death or serious injury.



CAUTION

Mishandling may cause hazardous situations resulting in moderate disability or minor injury, or property damage only.

Even if an instruction is classified as “CAUTION”, failure to observe may lead to serious results, depending on the situation. Since all the instructions are important, be sure to observe them.

Keep the Instruction Manual in a safe place for easy reference when necessary.

Be sure to deliver the Instruction Manual to a final owner who use the product.



WARNING

General

- Do not use the product for the following:
 1. Medical devices concerning sustaining and control of human life and body.
 2. Machinery and equipment for transfer and transportation of persons.
 3. Important stocked parts for machinery.
- Note that the product is not designed for purposes requiring high-level safety.

Installation

- Do not use the product in a place where hazardous materials such as ignitable materials, explosive materials, and inflammable materials. Failure to observe this may cause fire, explosion or ignition.
- When installing the product, be sure to fix it securely. Otherwise, drop or abnormal operation of it may cause injury.
- Avoid use of the product in a place where is exposed to droplets of water or oil.
- Be sure to provide Class D grounding. Otherwise, electric leakage may cause electric shock or malfunction.
- When connecting the product, always refer to the “instruction manual” to avoid miswiring. Failure to observe this may cause malfunction or abnormal operation.

Operation

- The product is not equipped with power failure protector. If the primary power supply is interrupted in the event of power failure or instantaneous power failure, the output voltage to the electromagnet is also interrupted. If power failure or instantaneous power failure may occur, be sure to additionally use a power failure protector (uninterruptible power system). Otherwise, attracted object may drop and cause injury.
- Avoid splash to the product. Splash or cleaning with water may cause abnormal operation and result in injury, electric shock or fire.
- Do not touch the terminal block and attach or detach I/O connector while the power is on. Otherwise, it may cause electric shock and or abnormal operation.
- Make sure that an attracting signal is not inputted and then turn on the power. If the power is turned on while the attracting signal is inputted, the electromagnet may start attraction and it may cause injury.
- If the product produces abnormal heat, smoke or odor, turn off the power immediately. If you continue to use it, the product may be damaged or ignited.
- If the protection function (alarm) of the product is activated, eliminate the cause completely before use. Abnormal operation of the product may cause injury, damage or failure of the product.
- If the indicator (display) of the product does not light, turn off the power immediately.

Maintenance and inspection

- Do not disassemble or modify the product. Otherwise, abnormal operation may cause injury, electric shock or fire.
- Be sure to turn off the power before maintenance or inspection. Failure to observe this may cause injury, electric shock or fire.

Disposal

- Do not put the product into fire. Failure to observe this may result in damage of the product or emission of toxic gas.

CAUTION

General

- Do not touch the heat radiating fin. It will get hot and cause skin burn.

Installation

- Use the product under the following environmental conditions. Failure to observe this may cause malfunction or abnormal operation.

1. Ambient temperature: -10 to 40°C
2. Humidity: 10 to 90% RH (without condensation)
3. No corrosive gas, explosive gas, oil mist, dust or steam.
4. Vibration: 4.9 m/s² (at vibration frequency of less than 20 Hz), 9.8 m/s² (vibration frequency of less than 50 Hz)
5. Altitude: Not more than 1,000 m

- Install the product on an indoor, well-ventilated location. For spacings from other equipment or in case of more than one unit used, refer to the drawing below.

Note that the spacings below are minimum. A cooling fan (※1) is incorporated at the top of the product. To achieve good ventilation, keep the top and bottom spacings as wide as possible.

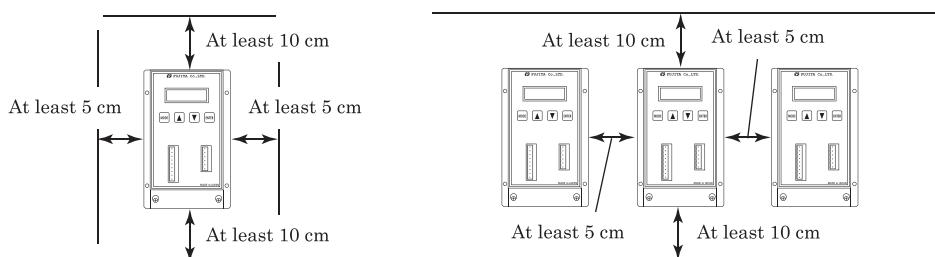

- ※1. The sensor of cooling fan monitors the temperature inside the product. When the temperature exceeds the set value, the fan starts rotation. It does not always rotate.

Request of selection

- Total current values of electromagnets which can be connected to the electromagnetic controller should be not more than 80% of the maximum output current of the controller.

If you intend to connect more than one electromagnet, refer to the following formula.

$$\text{Number of electromagnet capable of being controlled} = \frac{\text{Maximum output current of electromagnetic controller}}{\text{Current value of electromagnet}} \times 0.8 \text{ (margin)}$$

※When exporting (or providing to non-resident) articles requiring permission of export stipulated in the Foreign Exchange and Foreign Trade Act or falling within the cargo (or technology) subject to approval, permission of export, approval or permission of service transaction under the above Act is required.

Multiple floating bars Electromagnet

Type-FSGFM

PAT.



- Movable magnetic poles are compatible with various shapes of workpiece and therefore die changing is not required.
- Each workpiece can be transferred while it remains at the position of attraction.
- We can produce square type (※custom-made).

Specification

Model	Maximum attracting force N [kgf]	Voltage V	Current A	Duty factor %ED	Dimension							Weight Kg
					ΦD	H	Φd1	h1	P	M	c	
FSGFM-90	30 [3]	DC24	0.6	100	88	92	39.5	25	60	M6 Depth 7	20	2.1
FSGFM-110	100 [10]		1.0		112	104	56.5	30	80	M8 Depth 10		4
FSGFM-140	200 [20]	DC90	0.4		138	109	68.5		90	M8 Depth 11	25	5
FSGFM-160	300 [30]		0.6		162	119	99.5	35	120	M10 Depth 13		7.5

Outer dimension

FSGFM-90

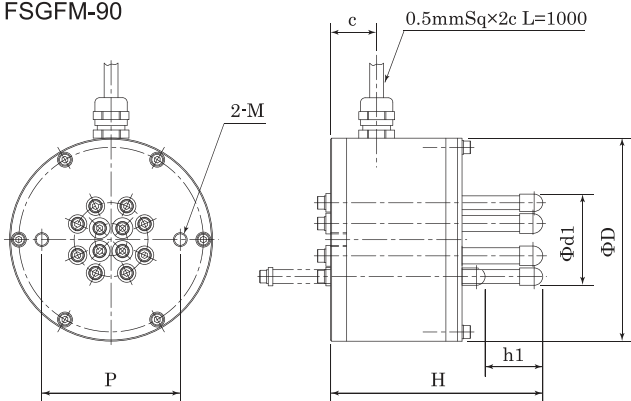

FSGFM-110

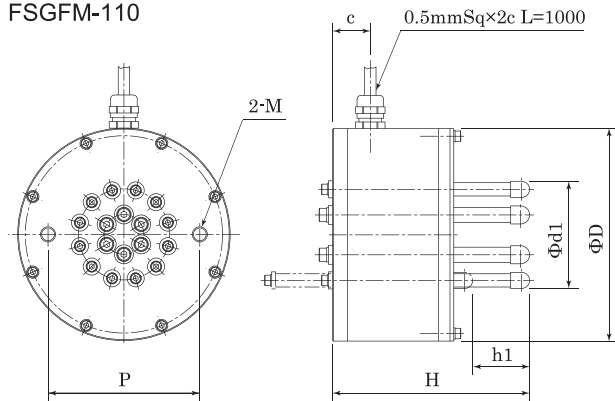

FSGFM-140

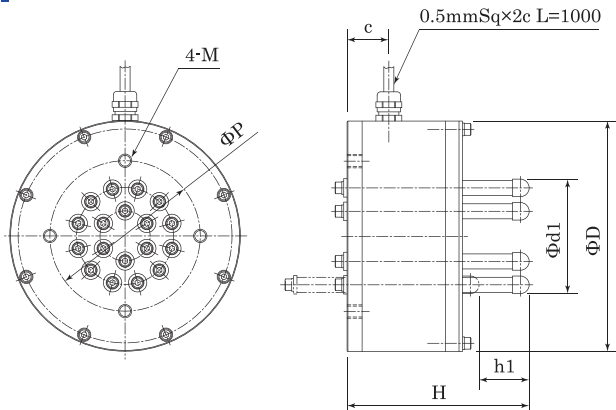

FSGFM-160

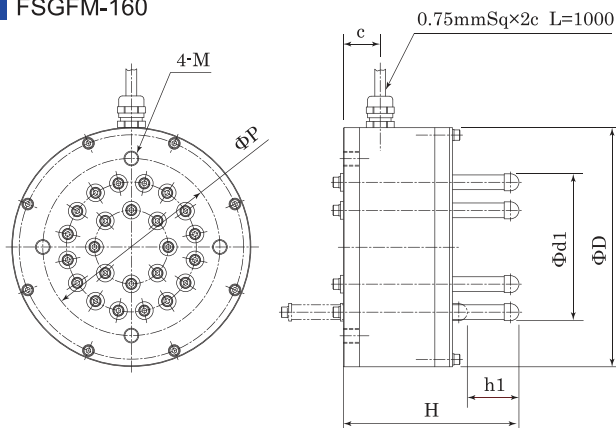

Notes :

- ※The maximum attracting force is the maximum value under the best conditions in case of attraction with all numbers of attracting magnetic pole.
- ※Since attracting magnetic poles are held with magnetic force when the electromagnet is energized, install it in consideration of the center of gravity of object of attraction, i.e. workpiece.

Cylindrical Electromagnet

Type-FSGP



- Numerous sizes are available for various kinds of workpiece.
- Small-sized, but strong attracting force.
- Capable of continuous use.

Specification

Model	Maximum attracting force N [kgf]	Voltage V	Current A	Duty factor %ED	Dimension							Weight Kg
					ΦD	H	M1	M2	P	a	S	
FSGP-20	28 [2.8]	DC24	0.07	100	20	40	M4 Depth 8	Φ2.1 Depth 2.5	7.5	7	0.3	0.06
FSGP-30	180 [18]		0.19		30		M6 Depth 12	Φ4 Depth 2	10			0.15
FSGP-40	400 [40]		0.24		40		Φ4 Depth 3	15	8.5			0.3
FSGP-50	600 [60]	DC90	0.12		50	50	M8 Depth 15	Φ5 Depth 4	18	9.5	0.5	0.56
FSGP-60	1100 [110]		0.19		60							12
FSGP-70	1500 [150]		0.2		60	M10 Depth 15	Φ6 Depth 6	20	15	1.4		
FSGP-80	2000 [200]		0.26							80	1.7	
FSGP-90	3300 [330]		0.35							90	2.2	

■ Thin type

Model	Maximum attracting force N [kgf]	Voltage V	Current A	Duty factor %ED	Dimension							Weight Kg
					ΦD	H	M1	M2	P	a	S	
FSGP-20D	18 [1.8]	DC24	0.07	100	20	25	M4 Depth 8	Φ2.1 Depth 2.5	7.5	7	0.3	0.03
FSGP-30D	80 [8]		0.19		30		M6 Depth 12	Φ4 Depth 2	10			0.1
FSGP-40D	220 [22]		0.24		40		Φ4 Depth 2.5	15	8.5			0.19
FSGP-50D	350 [35]	DC90	0.12		50	40	M8 Depth 15	Φ5 Depth 4	18	9.5	0.5	0.45
FSGP-60D	600 [60]		0.19		60				20	12		0.7

Outer dimension

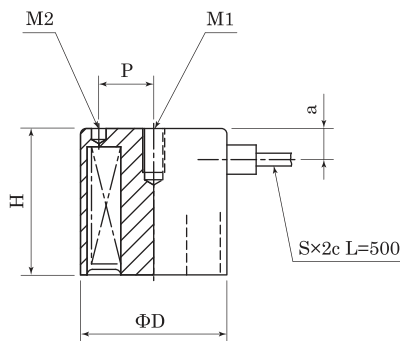

Notes :

※The maximum attracting force is the maximum value where the whole ground surface of SS400 plate with a thickness of 10mm.

Square Electromagnet

Type-FSGK

- Suitable for steel sheet and thin workpiece.
- Small-sized, but strong attracting force is secured.
- Capable of continuous use.



Specification

Model	Maximum attracting force N [kgf]	Voltage V	Current A	Duty factor %ED	Dimension				Weight Kg
					L	W	P	M	
FSGK-150-40/30	150 [15]	DC24	0.6	100	150	40	90	M5 Depth 15	0.9
FSGK-200-40/30	200 [20]		0.9		200		100		1.1
FSGK-250-40/30	280 [28]		1.1		250		120		1.4
FSGK-150-50/30	180 [18]		0.7		150	50	90	M6 Depth 15	1.2
FSGK-200-50/30	260 [26]		0.8		200		100		1.5
FSGK-250-50/30	350 [35]		1.2		250		120		1.8

Outer dimension

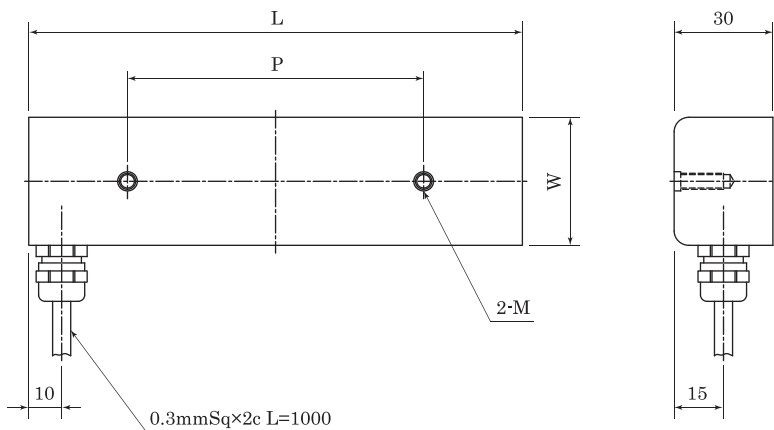

Notes :

※The maximum attracting force is the maximum value where the whole ground surface of SS400 plate with a thickness of 3mm.

Horseshoe Electromagnet

Type-FSGB

- Numerous sizes are available for various kinds of workpiece.
- Capable of continuous use.
- Change of attracting surface to V-shape (※custom-made) enables stable attraction of round bar, and so on.



Horseshoe Electromagnet Type-FSGB

Specification

Model	Maximum attracting force N [kgf]	Voltage V	Current A	Duty factor %ED	Dimension										Weight Kg
					L	W	H	a	b	P	M	S	Mount	Shape	
FSGB-75-25/55	120 [12]	DC24	0.3	100	75	23	55	3	15	40	M5 Depth 7	0.3	I	A	0.5
FSGB-100-25/55	180 [18]		50		0.6										
FSGB-100-40/59	800 [80]		100		1.3										
FSGB-150-40/59	1500 [150]		150		2										
FSGB-100-50/75	1700 [170]	DC90	0.2		100	50	75	9	10	45	M6 Depth 9	0.5	II	B	1.3
FSGB-150-50/75	2200 [220]		80		2										
FSGB-150-65/77	2500 [250]		150		4.2										
FSGB-200-65/77	3300 [330]		200		5.7										
FSGB-250-65/77	4200 [420]		250		6.8										
FSGB-150-75/77	3000 [300]		150		5										
FSGB-200-75/77	4000 [400]		200		6.6										
FSGB-250-75/77	5000 [500]		250		8.2										

Outer dimension

Shape : A

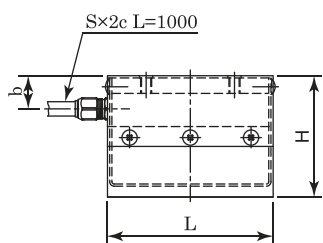

Shape : B

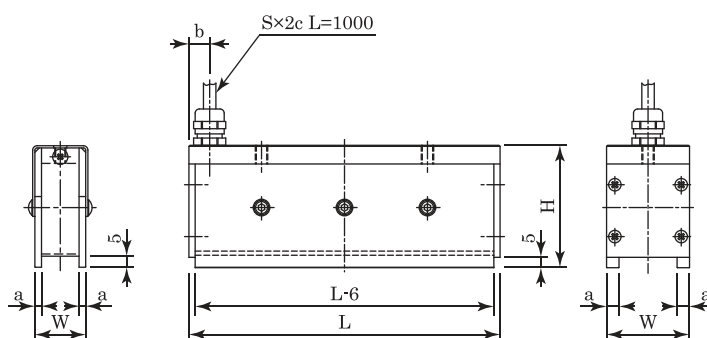

Mount holes : I

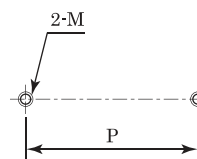

Mount holes : II

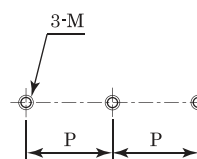

Notes :

※The maximum attracting force is the maximum value where the whole ground surface of SS400 plate with a thickness of 10mm.

Stick Electromagnet

Type-FSGS

- Point-contact type to be compatible with different shapes of workpiece such as castings and forgings.
- Point-contact type, but strong attracting force is secured.
- The attracting tip can be replaced.



Specification

Model	Maximum attracting force N [kgf]	Voltage V	Current A	Duty factor %ED	Dimension									Weight Kg	
					ΦD	H	Φd1	a	b	P	M	c	S		
FSGS-5·6	3 [0.3]	DC24	0.3	100	50	60	10	40	-	30	M6 Depth 7	16	0.3	0.7	
FSGS-6·8	6 [0.6]		0.5		60.5	80	12	52		40	M6 Depth 9	17	0.5	1.1	
FSGS-7·10	30 [3]		0.8		76.3	100	25	25	25	50	M8Depth 12	22	0.75	2.8	
FSGS-9·12	50 [5]		1.3							60	M10 Depth 14	27	1.25	4.8	
FSGS-11·16	130 [13]	DC90	0.6		100	114.3	160	35	30	30	80	M12 Depth 20	37	2.0	10
FSGS-14·18	200 [20]		0.9			139.8	180	40			40	M16 Depth 22			50
FSGS-16·23	280 [28]		1.4			165.2	230	55	45	35	100	M16 Depth 24	55	3.5	30

Outer dimension

FSGS-5·6 / 6·8

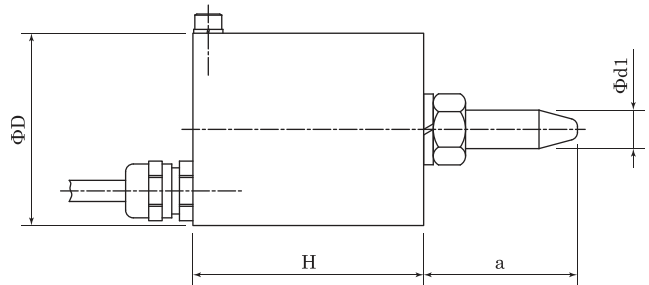

FSGS-7·10 to 16·23

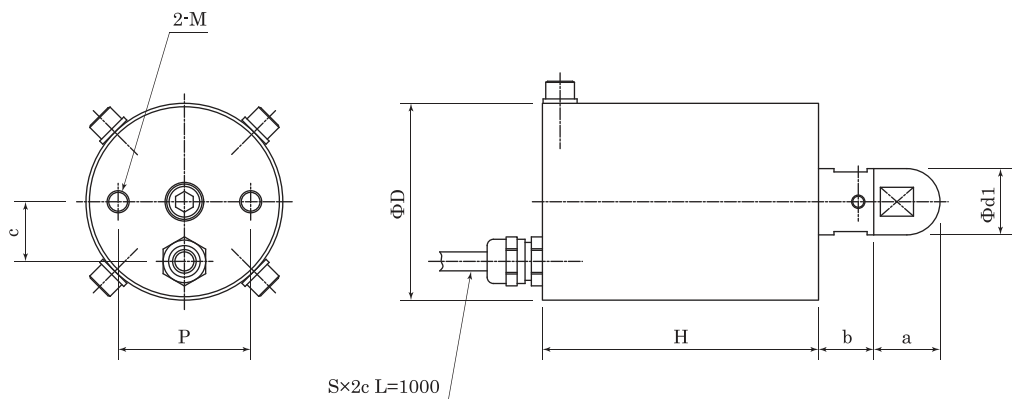

Ring Electromagnet

Type-FSGT

- Optimum for thin workpiece such as pressed article.
- Thin structure allowing space saving installation in a press.
- Top cable outlet type or other type is available (※custom-made).



Specification

Model	Maximum attracting force N [kgf]	Voltage V	Current A	Duty factor %ED	Dimension									Weight Kg		
					ΦD	Φd1	Φd2	H	h1	ΦP	M	a	Mount			
FSGT-100-50	200 [20]	DC24	0.55	100	100	50	60	35	5	80	M5 Depth 6	15	I	1		
FSGT-110-60	250 [25]		0.66		110	60	70			90	M6 Depth 6			1.1		
FSGT-120-70	350 [35]		1		120	70	82			37	1.4					
FSGT-140-80	650 [65]		1.2		140	80	94	45		116	M6 Depth 8			2.3		
FSGT-160-90	700 [70]	DC90	0.4		100	160	90	106	10	50	130	M8 Depth 10	18	II	3.1	
FSGT-170-100	750 [75]		0.48			170	100	116			140				3.7	
FSGT-185-120	850 [85]		0.72			185	120	140			160	M8 Depth 12			20	4.1

Outer dimension

Mount holes : I

Mount holes : II

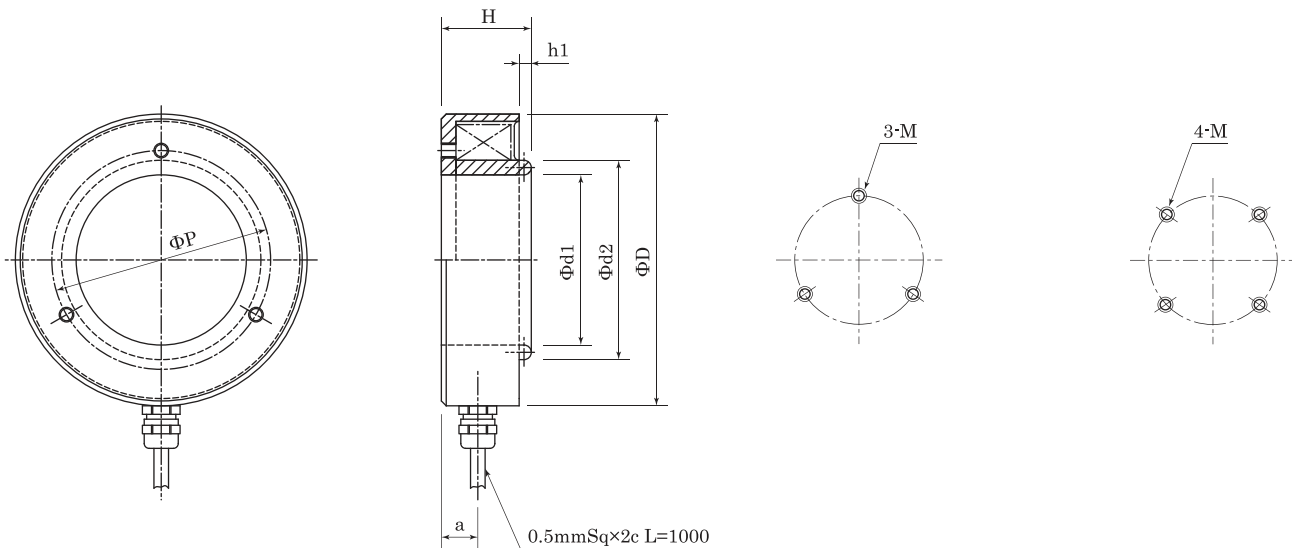



Notes :

※The maximum attracting force is the maximum value where the whole ground surface of SS400 plate with a thickness of 10mm.

Important information on Electromagnet

For correct use of the electromagnet, be sure to read carefully these “Safety Precautions” and Instruction Manual packaged with the product before installation, operation, maintenance and inspection of it.

In this manual, the safety precautions are classified into “WARNING” and “CAUTION”.

 WARNING	Mishandling may cause hazardous situations resulting in death or serious injury.
 CAUTION	Mishandling may cause hazardous situations resulting in moderate disability or minor injury, or property damage only.

Even if an instruction is classified as “CAUTION”, failure to observe may lead to serious results, depending on the situation.

Since all the instructions are important, be sure to observe them.

Keep the Instruction Manual in a safe place for easy reference when necessary.

Be sure to deliver the Instruction Manual to a final owner who use the product.

Principle

- Applying direct current to the coil of electromagnet produces attracting magnetic force, which attracts magnetic substance such as iron.

WARNING

- If magnetic materials such as iron get close to the electromagnet while the current is flown to its coil, it attracts. Be careful to prevent your hand or leg from being inadvertently trapped.
- Never get your body, hand or leg below suspended object. If it drops, it may cause serious accident.

How to use

- Use the electromagnet with the power within the voltage range marked on it.
- Connect one end of the cord to the positive terminal of power supply and the other end to the negative terminal.
- When a voltage is applied to the electromagnet, it is excited and attracts magnetic substance such as iron.

CAUTION

- If you use the electromagnet with a voltage exceeding the marking, it may cause burning the electromagnet.
- The electromagnet is not waterproof. Ingress of water may cause breakdown and prevent use.
- Use the electromagnet at ambient temperature not exceeding 40°C and at the temperature of attracted object not exceeding 50°C. Failure to observe this may cause burning of the electromagnet.

Residual attracting force

- Just an interruption of current flown to the coil of electromagnet may not be able to cause detachment of attracted magnetic substance due to residual attracting force resulting from residual magnetism. For smooth detachment, we recommend you use the electromagnetic controller, Model FSCG or FSCE.

Characteristics of attracting force

- Maximum attracting force

Maximum attracting force described in the catalog and Instruction Manual is based on the assumption that the attraction is made with its whole attracting surface under the most suitable conditions such as material of attracted object, thickness, finished surface.

■ Relationship between thickness and attracting force

Attracting force significantly differs depending on the thickness of attracted object.

[Reference material]

The relationship between thickness of cylindrical electromagnet Type-FSGP and its attracting force is as shown below.

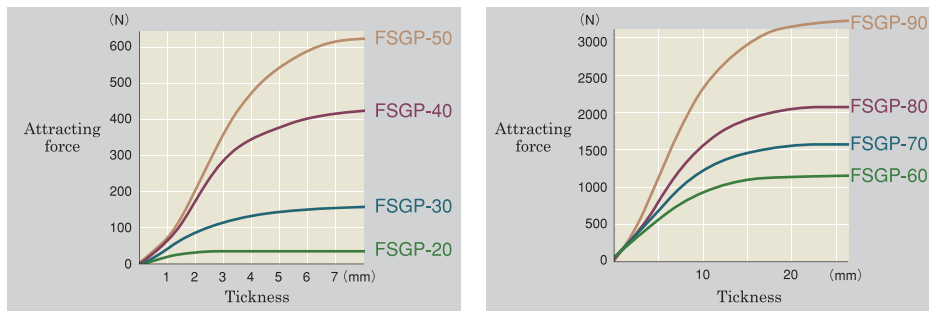

■ Relationship between gap and attracting force

Attracting force significantly differs depending on the gap between attracting surface and attracted object.

[Reference material]

The relationship between the gap of cylindrical electromagnet Type-FSGP and its attracting force is as shown below.

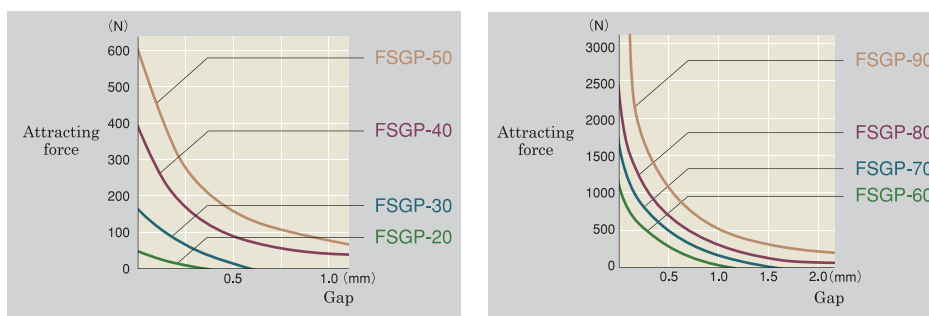

■ Relationship between material and attracting force

Attracting force significantly differs depending on the material or heat treatment of attracted object.

The following graph shows the percentage of attracting force of each material, assuming that the attracting force of SS400 is deemed as 100%.

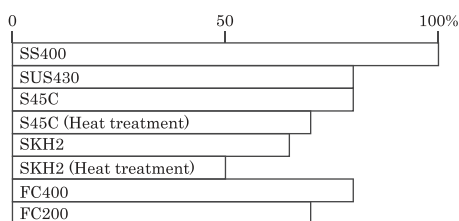

■ Relationship between surface roughness and attracting force

Attracting force significantly differs depending on the surface roughness of attracted object. The following graph shows the percentage of attracting force with surface roughness, assuming that the attracting force with ground surface of SS400 is deemed as 100%.

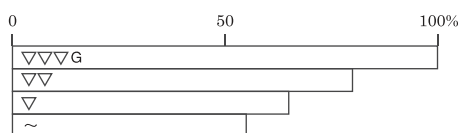

CAUTION

- When selecting an electromagnet, consider carefully the conditions of attracted object such as thickness, shape, attraction area, material, heat treatment, and those of transfer such as vibration of equipment, size of gap, center of gravity of attraction. If you feel difficult to select an electromagnet, contact us in advance.

Related products including magnetic separators are also available.

Table type demagnetizer
FTMD

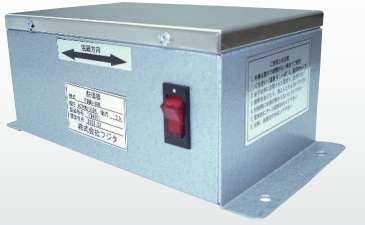

It produces alternating magnetic field on a demagnetizing surface by AC power supply, transfers a workpiece in its magnetic field area and demagnetizes the workpiece.

Tunnel type demagnetizer
FTMDT

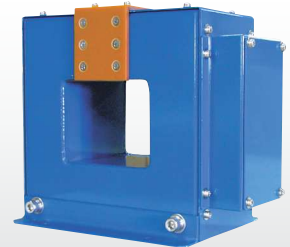

It can be used to pass small parts contained in a bucket or for a production line with a conveyor which continuously transfers those parts. It can be also used for long object or single part.

Parmanent magnet separator
FCSF



It can be used for detaching a piled steel sheet one by one during pressing or shirring and for inserting it into a machinery.

Permanent magnet roller
FCPR



It can be used for transfer of steel pipe or steel material (including stop of transfer), anti-slip and attraction and transfer in automation.

Simple magnet plate
FMP

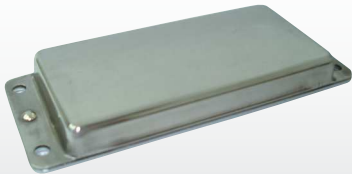

It can be used for attraction of metallic materials in a liquid such as lubricating oil for plating bath, as well as for assistance of transfer of magnetic material, if it is attached to a conveyor.

Permanent magnet pulley
FTPR

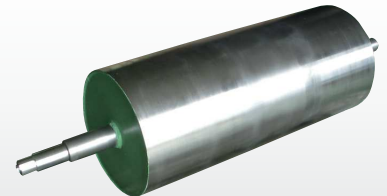

It can be used for removal of iron powders in powder materials in food/chemical industry, steel manufacturing, coal industry, mining and manufacturing, etc.

Suspended permanent magnetic separator
FTPS

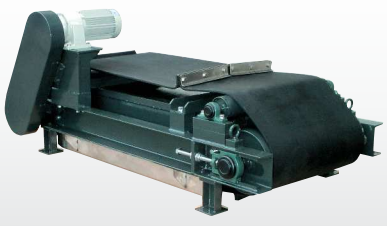

It can be used for removal of iron from raw materials and products in food/chemical industry and waste treatment system.

Drum type permanent magnetic separator
FTDS



It can be used for fast, automated magnetic separation and ejection of iron powders from powders and granules in dry type separator.

If you have any question about magnet, feel free to contact us.



Please feel free to contact us for questions or detailed information material for electromagnet control system.



FUJITA Co.,LTD.

375-1 Izumi, Kuwana City, Mie Prefecture, Japan 511-0838

TEL : +81-594-213321 FAX : +81-594-23-4491

※Model, appearance or specification of products described in this catalog may be subject to change without notice.